

# DESIGN NOTES

## Tiny Monolithic Step-Down Regulators Operate with Wide Input Range – Design Note 390

Kevin Huang

### Introduction

Automotive batteries, industrial power supplies, distributed supplies and wall transformers are all sources of wide-ranging high voltage inputs. The easiest way to step down these sources is with a high voltage monolithic step-down regulator that can directly accept a wide input range and produce a well-regulated output. The LT<sup>®</sup>3493 accepts inputs from 3.6V to 36V and LT3481 accepts inputs from 3.6V to 34V. Both provide excellent line and load regulation and dynamic response. The LT3481 offers a high efficiency solution over a wide load range and keeps the output ripple low during Burst Mode<sup>®</sup> operation while the LT3493 provides a tiny solution with minimal external components. The LT3493 operates at 750kHz and the LT3481 has adjustable frequency from 300kHz to 2.8MHz. High frequency operation enables the use of small, low cost inductors and ceramic capacitors.

### Low Ripple and High Efficiency Solution over Wide Load Range

The LT3481 is available in a 10-pin MSOP or a 3mm × 3mm DFN package with an integrated 3.8A power switch and external compensation for design flexibility. The switching frequency can be programmed from 300kHz to 2.8MHz by using a resistor tied from the RT pin to ground. Figure 1 shows the LT3481 producing 3.3V at 2A from an input of 4.5V to 34V. Figure 2 shows the circuit efficiency at 12V input.

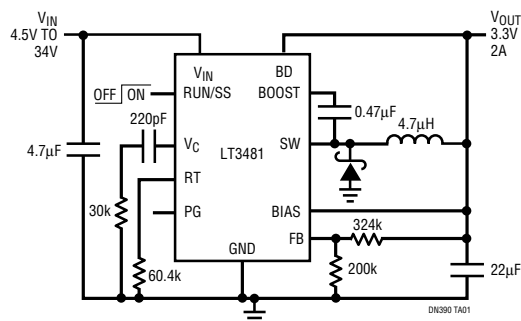

Figure 1. 800kHz LT3481 DC/DC Converter Delivers 2A at 3.3V Output

The LT3481 offers low ripple Burst Mode operation that maintains high efficiency at light load while keeping the output voltage ripple below 15mV<sub>p-p</sub>. During Burst Mode operation, the LT3481 delivers single cycle bursts of current to the output capacitor followed by sleep periods when the output power is delivered to the load by the output capacitor. Between bursts, all circuitry associated with controlling the output switch is shut down reducing the input supply current to 50µA. Figure 3 shows the inductor current and output voltage ripple under single pulse Burst Mode operation from 12V input to 3.3V output. As the load current decreases to a no load condition, the percentage of time that the LT3481 operates in sleep mode increases and the average input current is greatly reduced resulting in high efficiency. The LT3481 has a very low shutdown current (less than 1µA) which significantly extends battery life in applications that spend long periods of time in sleep or shutdown mode.

The high side bootstrapping boost diode is integrated into the IC to minimize solution size and cost. When the output voltage is at least 2.8V, the anode of the boost diode can be connected to output. For output voltages lower than 2.5V, the boost diode can be tied to the input. For systems that rely on a well-regulated power source, the LT3481 provides a power good flag that signals when V<sub>OUT</sub> reaches 90% of the programmed output voltage. A

LT, LT, LTC, LTM and Burst Mode are registered trademarks of Linear Technology Corporation. All other trademarks are the property of their respective owners.

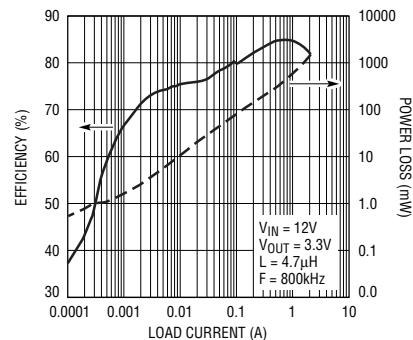
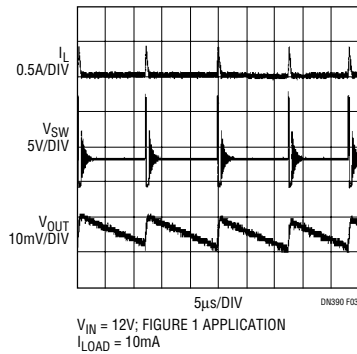
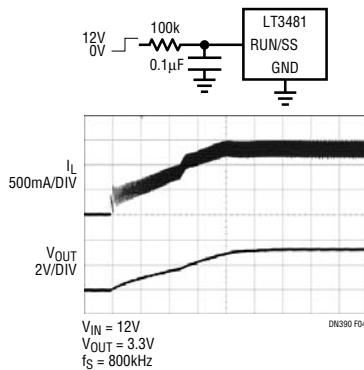

Figure 2. Efficiency vs Load Current for Figure 1 Circuit



**Figure 3. LT3481 Burst Mode Operation at 10mA Load Current**

resistor and capacitor on the RUN/SS pin programs the LT3481's soft-start, reducing maximum inrush current during start-up. Figure 4 shows the circuit and start-up waveform.



**Figure 4. Soft-Start of the LT3481**

### Small Solution Size

The LT3493 includes an internal 1.75A power switch in a tiny 6-pin DFN package (2mm × 3mm). The current mode control circuit with its internal loop compensation eliminates external compensation components, minimizing component count and reducing the PC board space to less than 50mm<sup>2</sup>. The LT3493's reference voltage is 0.78V, making it suitable for applications with low output voltage. Figure 5 shows an application of the LT3493 switching at 750kHz. This circuit generates 3.3V from an input of 4.2V to 36V. In applications where the circuit is plugged into a live input source through long leads, a high

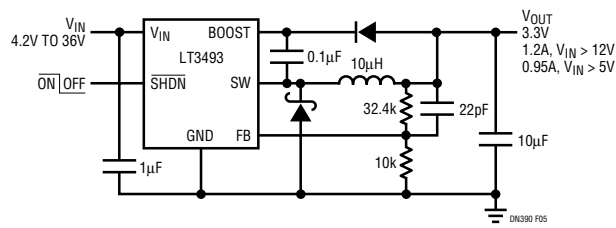

**Figure 5. LT3493 Wide Input Range DC/DC Converter Application to 3.3V**

ESR electrolytic capacitor at the input is recommended to damp the overshoot voltage. Refer to AN88 for details. The SHDN pin can be driven through an external RC filter to soft-start the LT3493.

### Additional Features of LT3481 and LT3493

During short circuit, both parts offer cycle-by-cycle current limit and frequency foldback which decreases the switching frequency when the output is low. The low frequency allows the inductor current to safely discharge.

### Conclusion

The wide input ranges, small size and robust design of the LT3493 and LT3481 make them an excellent choice for a wide variety of step-down applications. Their high input voltage, high power switch capability and excellent package thermal conductivity add to their versatility.

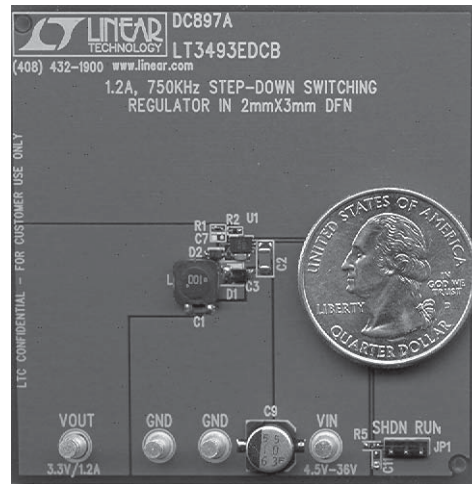

**Figure 6. LT3493 Demo Board**

[Data Sheet Download](#)

[www.linear.com](http://www.linear.com)

For applications help,  
call (408) 432-1900, Ext. 2759